



Status of the Beaufort Gyre Observing System (BGOS, 2003-2015)

Andrey Proshutinsky, Woods Hole Oceanographic Institution, USA
Richard Krishfield, Woods Hole Oceanographic Institution, USA
John Toole, Woods Hole Oceanographic Institution, USA
Mary-Louise Timmermans, Yale University, USA
Bill Williams, Institute of Ocean Sciences, DFO, Canada
Eddy Carmack, Institute of Ocean Sciences, DFO, Canada
Fiona McLaughlin, Institute of Ocean Sciences, DFO, Canada,
Koji Shimada, Tokyo University of Marine Science and Technology, Japan

Robust Autonomous Arctic Observations: Successes and Challenges

18 November 2015

2:00 – 2:15 pm

**2015 Arctic Observing Open Science Meeting
Seattle, Washington, USA**



**Fisheries and Oceans
Canada**

**Pêches et Océans
Canada**





BGOS: Funding history

2003-2004: Beaufort Gyre Freshwater Experiment: Study of fresh water accumulation and release mechanism and a role of fresh water in Arctic climate variability – NSF

2004-2005: Beaufort Gyre Freshwater Observing System – WHOI

2005-2009: The Beaufort Gyre System: Flywheel of the Arctic Climate? – NSF

2009-2014: AON: Continuing the Beaufort Gyre Observing System to Document and Enhance Understanding Environmental Change in the Arctic – NSF

2015-2018: AON – Continuing the Beaufort Gyre Observing System to Document and Enhance Understanding of the Beaufort Gyre Freshwater Reservoir Transformations and Fate – NSF

Beaufort Gyre circulation cell and freshwater reservoir



- Greater than half of the total Arctic Ocean's liquid fresh water is stored in the Canada Basin with its Beaufort Gyre (BG) which contains more than 20,000 km³ of liquid fresh water (i.e. Aagaard and Carmack, 1989).

- The volume of freshwater in the BG is practically identical to the volume of fresh water in Lake Baikal (23,000 km³), the largest lake on the Earth, and is comparable with fresh water volume stored in all Great Lakes (23,000 km³). The BG volume is at least 5 times larger than the total annual river runoff to the Arctic Ocean and approximately two times larger than the volume of fresh water stored in Arctic sea ice .

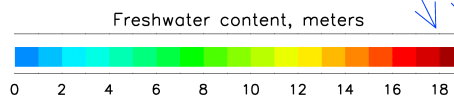
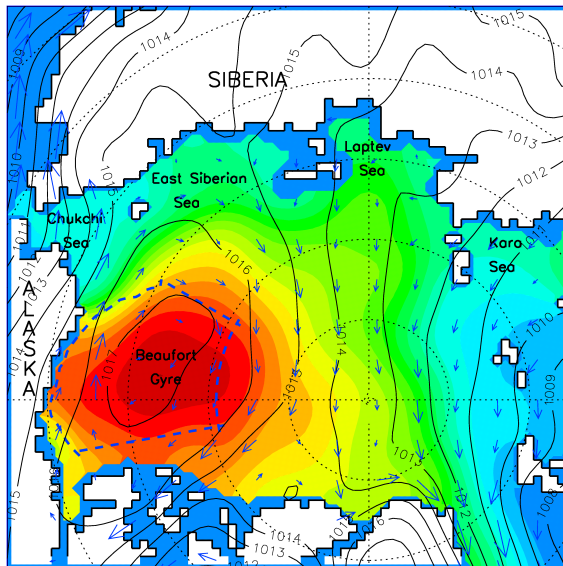

- The BG has a capability to impact climate releasing large volumes of freshwater to the Labrador and Nordic Seas and inhibiting deep convection there, that may reduce intensity of the ocean meridional overturning circulation and result in climate cooling.



Questions and Hypotheses

Freshwater accumulation and release mechanisms

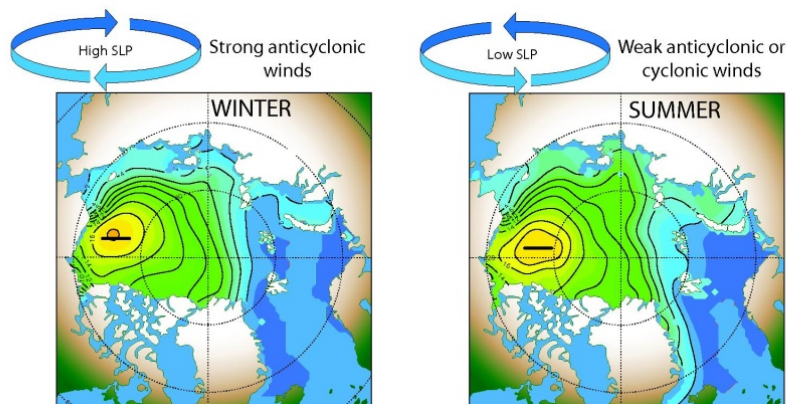

Fresh Water (FW) content:
Arctic Ocean = 61,463 km³
Canada Basin = 41,516 km³

Mechanically, BG accumulates FW and FW gradients sharpen. But sea ice grows, salt is released and FW content in the BG decreases.

Fresh Water (FW) content:
Arctic Ocean = 74,713 km³
Canada Basin = 44,497 km³

Mechanically, BG releases FW and FW gradients smooth. But sea ice melts and river runoff increases and FW content in the BG increases.

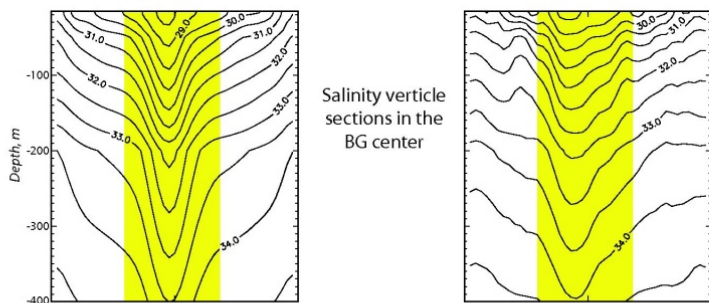

- **What is the origin of the salinity minimum in the BG?**
- **How does this salinity or freshwater content change in time?**
- **What are the driving forces of the BG circulation and how stable is the BG system?**

Proshutinsky et al. [2002] hypothesized that the BG collects freshwater in its center under anticyclonic winds due to convergence of Ekman transport and subsequent Ekman pumping; and releases it when wind weakens or changes sense

to cyclonic and the Ekman transport convergence reduces or changes to divergence, respectively.



Beaufort Gyre Observing System (BGOS)

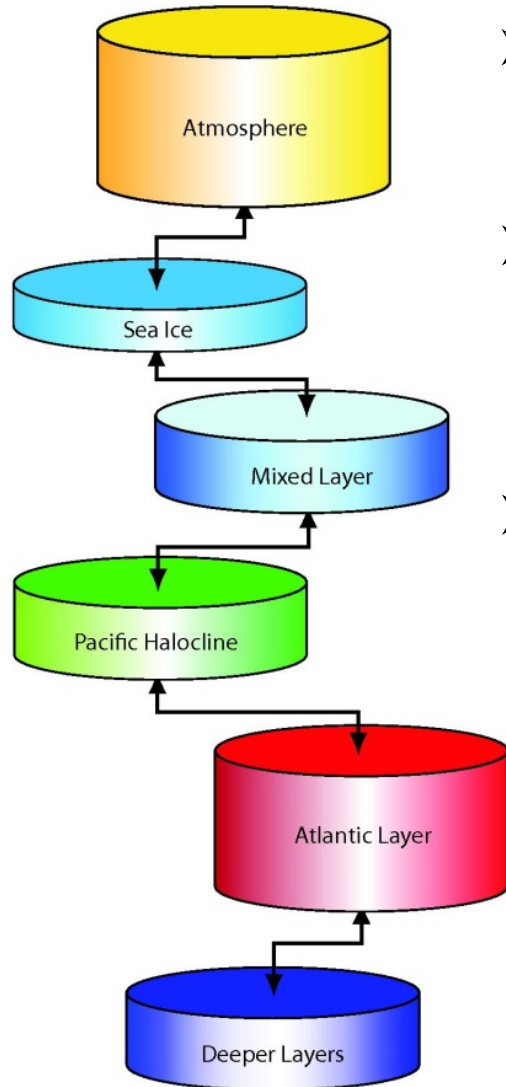

- In order to test this hypothesis, the BG Observing System (BGOS) was established in 2003 as a part of the Beaufort Gyre Exploration Project.
- Later, this project has been continued and expanded because of importance of the BG freshwater reservoir for climatic changes in the Arctic and Subarctic regions.
- The BGOS was designed to observe and investigate year-round and long-term changes associated with freshwater and heat fluxes in the entire BG climate system at standard locations measuring all possible water, ice and environmental parameters which can explain fresh water transformations (liquid and solid) and changes under variable sources and forcing.



BGOS: geography and standard observational sites

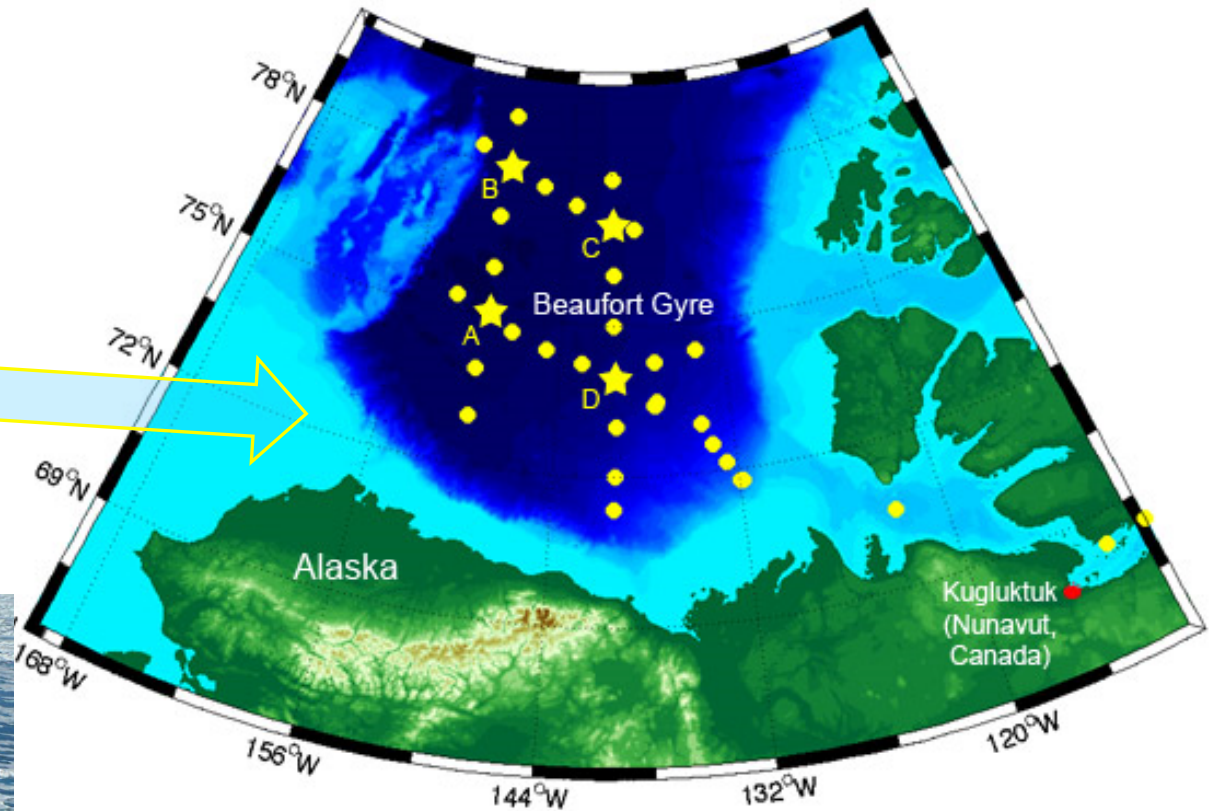
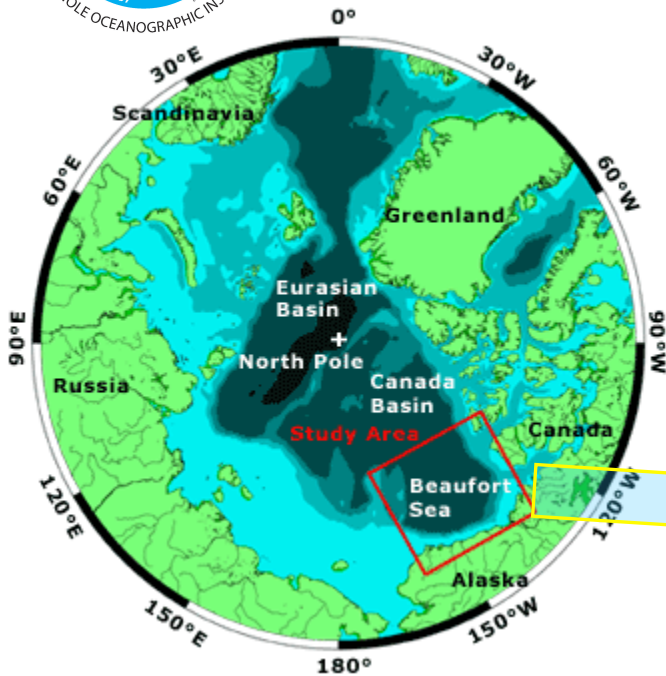

Canadian Coast Guard icebreaker
Louis S. St. Laurent

2003 -2018

Standard mooring (stars) and CTD (circles) sites

BGOS: Instrumentation

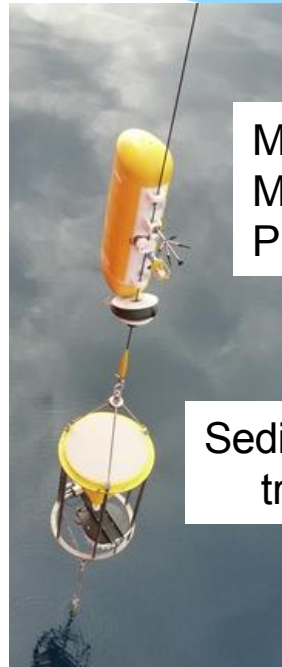
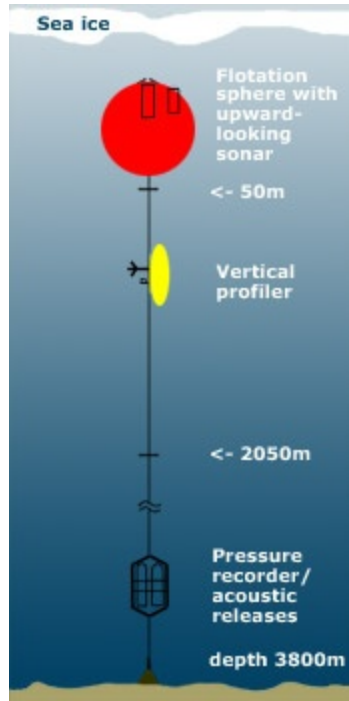

McLane Moored Profiler



Seismic work



Upward-looking sonar

Sediment trap



CTD



Bongo nets



ADCP



BPR



Ice-Tethered Profiler

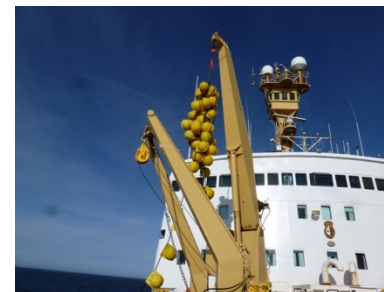

BGOS deployments/recoveries

Year	CTD	XCTD	ITP	IMB	AOFB	O-buoy	Moor-s
2003	47	84					3
2004	36	80	1/0	1/0			3/3
2005	51	43	2/0	2/0			5/3
2006	75	55	3/0	2/0	2/0		4/5
2007	105	74	3/2	1/0	2/0		4/4
2008	73	104	5/0	1/0	2/0		3/4
2009	53	56	4/2	1/0	1/0	1/0	3/3
2010	72	59	4/1	2/0	2/0	1/1	3/3
2011	52	49	3/0	3/0	3/0	1/0	3/3
2012	56	108	4/0	3/0	2/0	2/0	5/4
2013	52	88	4/0	3/0	2/0	1/0	5/5
2014	40	65	2/3	2/0	2/0	2/0	3/3
2015	70	54	2/0	2/0	1/0	2	3/4
Total	782	919	37/8	23/0	20/0	10/1	47/45



BGOS: measured parameters

A. Standard

1. Ocean physical parameters: *T, S, currents, bottom pressure*
2. Sea ice: *Draft, drift*
3. Biogeochemistry: *CFC, O₂, TCO₂, ¹³C, DOC, Helium & Tritium, ¹⁴C, Nutrients, ¹⁸O, Ba, Iodine, Cesium, Chl-a-T, Chl-a-10/2, POC, C-DOM, CHO, HCH*

B. Non-standard by other programs using BGOS logistics

- Lowered ADCP
- Sediment traps
- Zooplankton sampling
- Sea ice physical and chemical properties
- Wildlife observing
- Seismology
- Turbulence measurements
- Buoys: Up-Tempo, IMBs, O-buoys, AOFB, ITPs, SAMs – IBOs, polar profiling floats
- Drift bottles
- Media filming

USA institutions

1. Yale University, New Haven, US
2. Bigelow Laboratory for Ocean Sciences, USA
3. Cold Regions Research Laboratory, USA
4. Lamont Doherty Earth Observatory, USA
5. University of Rhode Island, USA
6. Pacific Marine Environmental Laboratory, NOAA, USA
7. Oregon State University, USA
8. Pacific Marine Sciences and Technology LLC, USA
9. University of Alaska Fairbanks, USA
10. University of Akron, Akron, USA
11. University of Montana, Missoula, USA
12. International Arctic Research Center, USA
13. Naval Postgraduate School, USA

Canada institutions

1. University of Victoria, British Columbia, Canada
2. Natural Resources Canada
3. University of Laval, Canada
4. Trent University, Peterborough, Ontario, Canada
5. University of British Columbia, British Columbia, Canada
6. University of Montreal, Montreal, Quebec, Canada
7. Institute of Ocean Sciences, DFO, Canada
8. Environment Canada

Japan institutions

1. JAMSTEC, Japan
2. Tokyo University of Marine Science and Technology, Japan
3. Weathernews Inc., Mihama, Chiba, Japan
4. Kitami Institute of Technology, Kitami, Hokkaidō, Japan

UK institutions

1. SAMS Scottish Association for Marine Science, UK
2. The Environment of the Arctic – Climate, Ocean and Sea-Ice, UK
3. Bangor University, Wales, UK

China institutions

1. Ocean University China, China

BGOS: other participants

Poland institutions

1. Institute of Oceanology, Poland

Korea institutions

1. KOPRI Korea Polar Research Institute, Korea

Media relations

1. ABC Asahi Broadcasting Company, Japan
2. Educational Broadcasting System (EBS), Korea
3. National Broadcasting Company (NBC)
4. National Television, NTV (Russia)



All CTD & ITP Profiles: 2004-2015

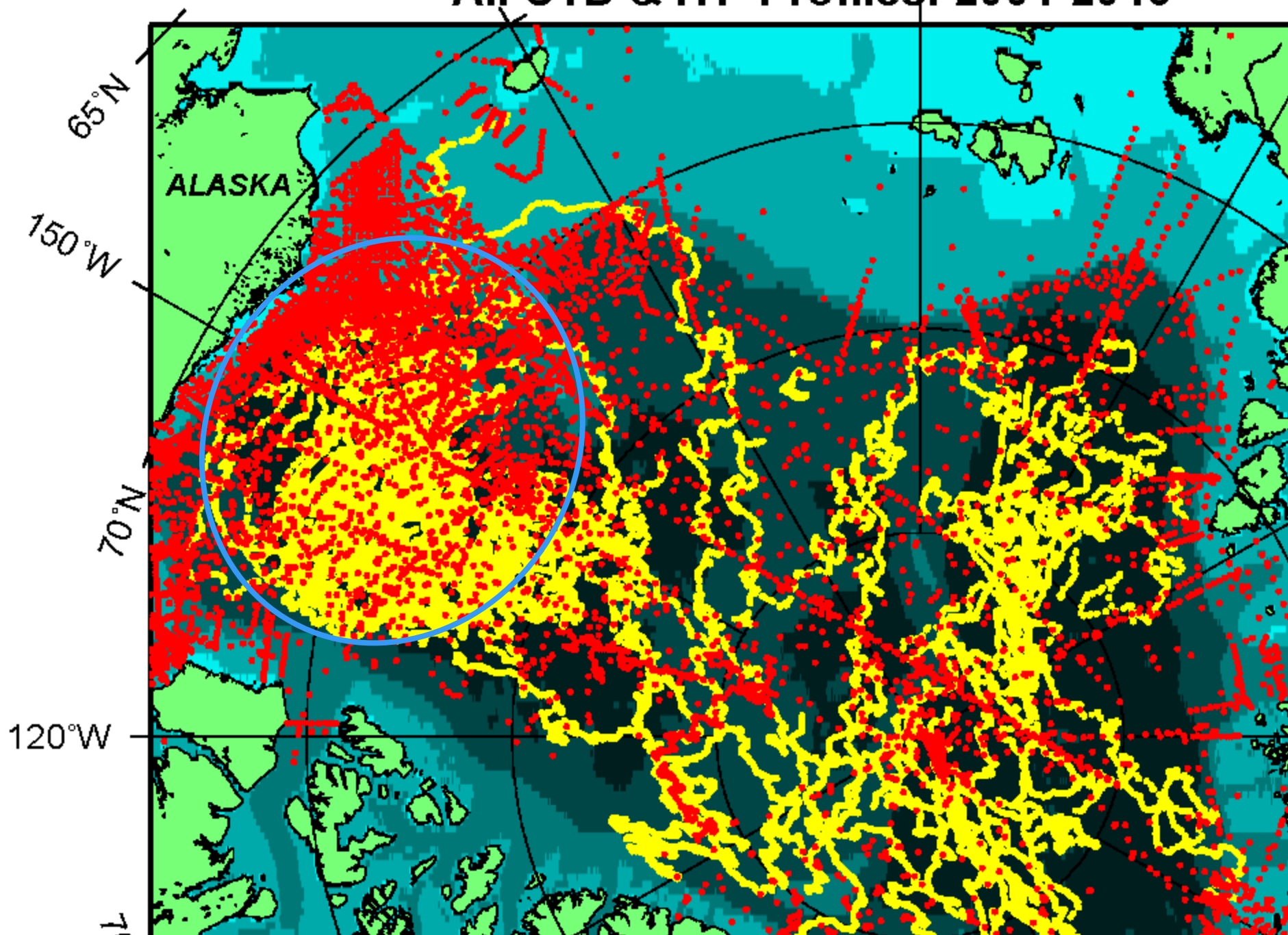

BGOS major results: publications

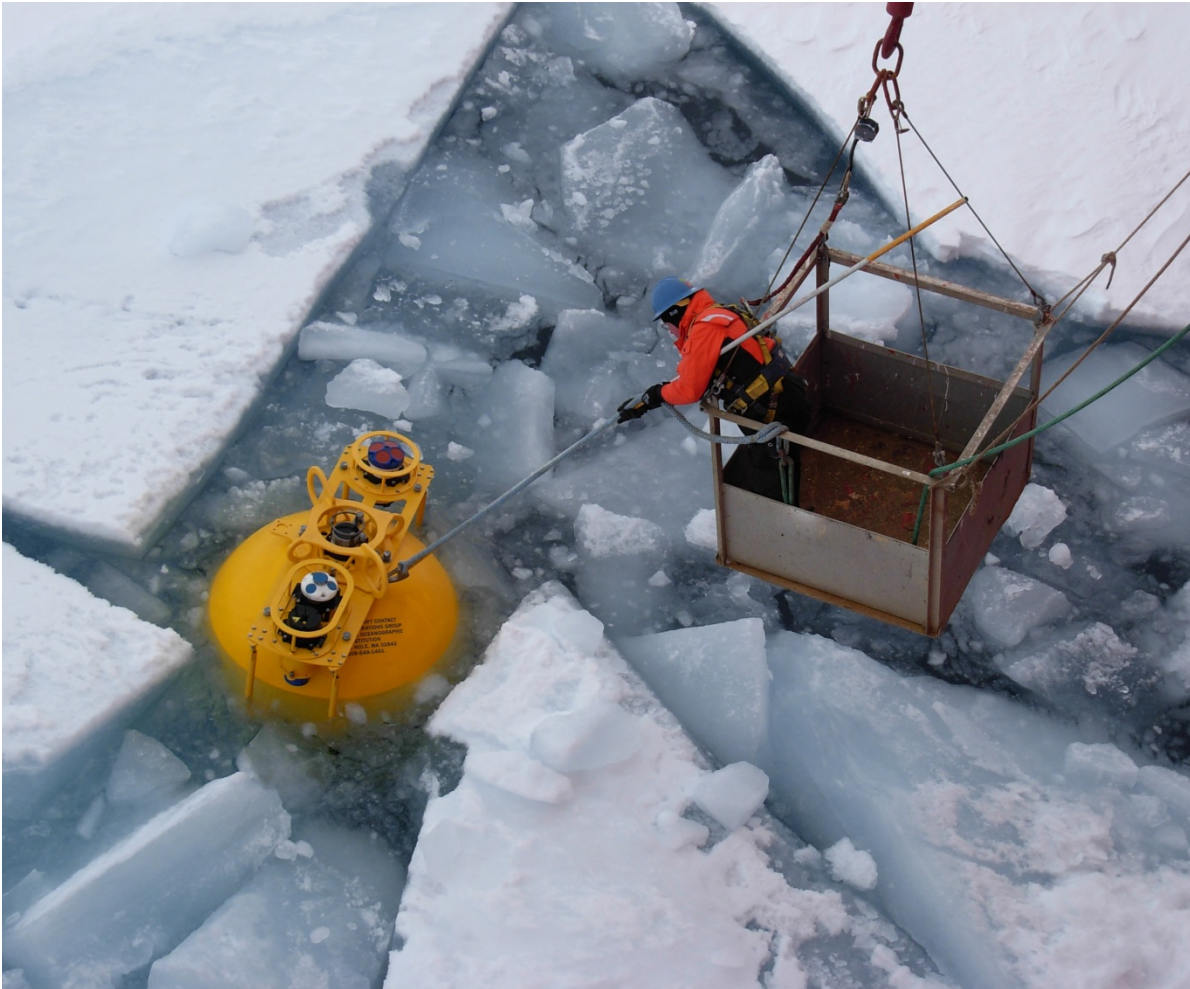

The first program results for 2003-2007 were published in JGR special section “Beaufort Gyre Climate System Exploration Studies” (JGR Oceans, vol. 115, no. C1, 2010).

To date, over 80 peer-reviewed publications have utilized BGOS data.



BGOS major findings

Hydrography: Hydrographic data indicate that liquid fresh water in the BG in summer increased 5410 cubic km from 2003 to 2010 and decreased a bit in 2011-2014 but in 2015 it reached its absolute maximum of 22,600 cubic km or 5600 cubic km over climatology of the 1950s-1980s.

Sea ice: Negative trends in ice drafts are observed, while open water fraction has increased, attesting to the ablation or removal of the older sea ice from the BG over the observational period. A shift occurred toward thinner ice after 2007. (Krishfield et al., 2014)

BGOS major results: Freshwater

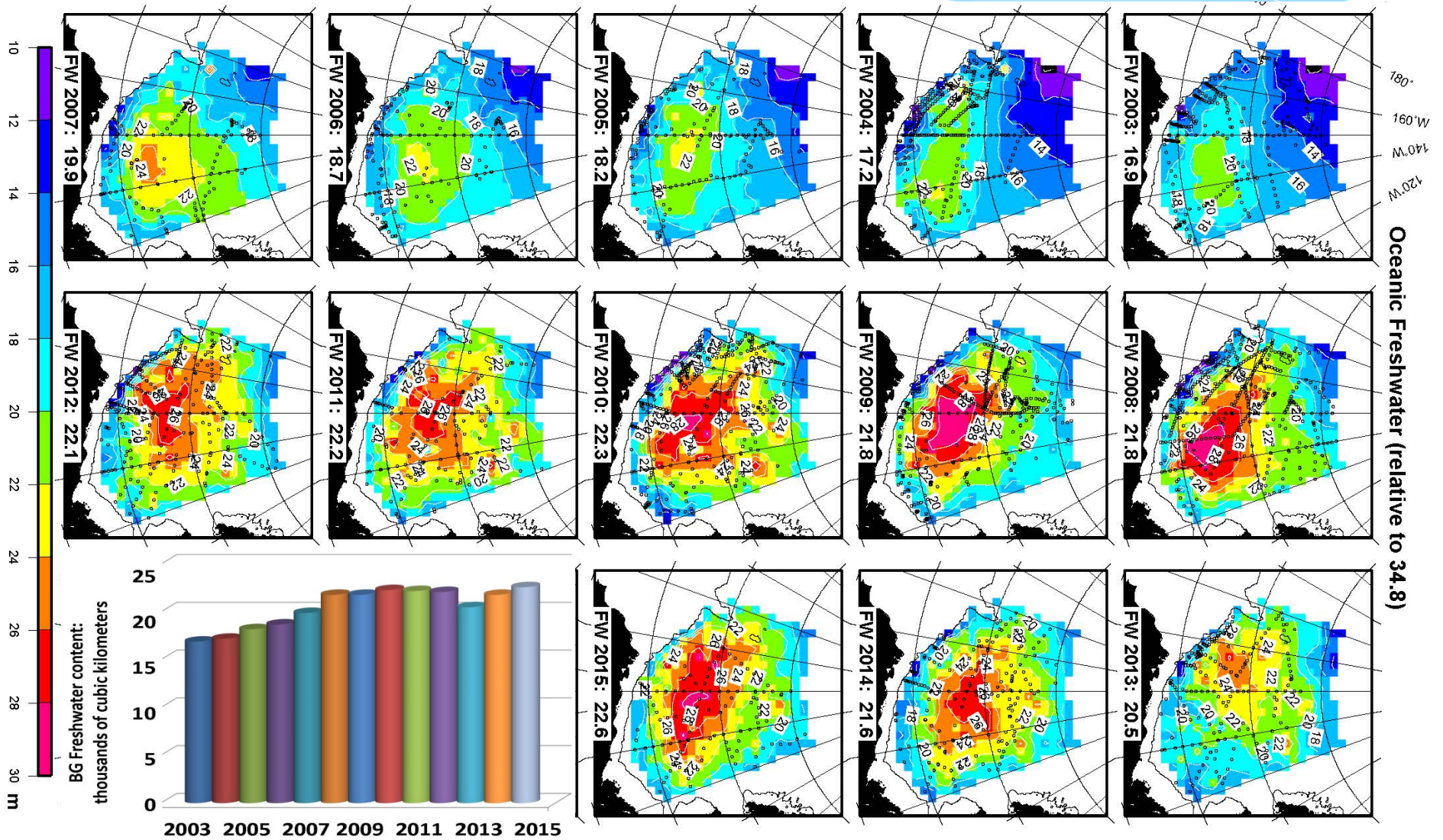

BGOS major results: Freshwater



- Annual river runoff to the Arctic Ocean

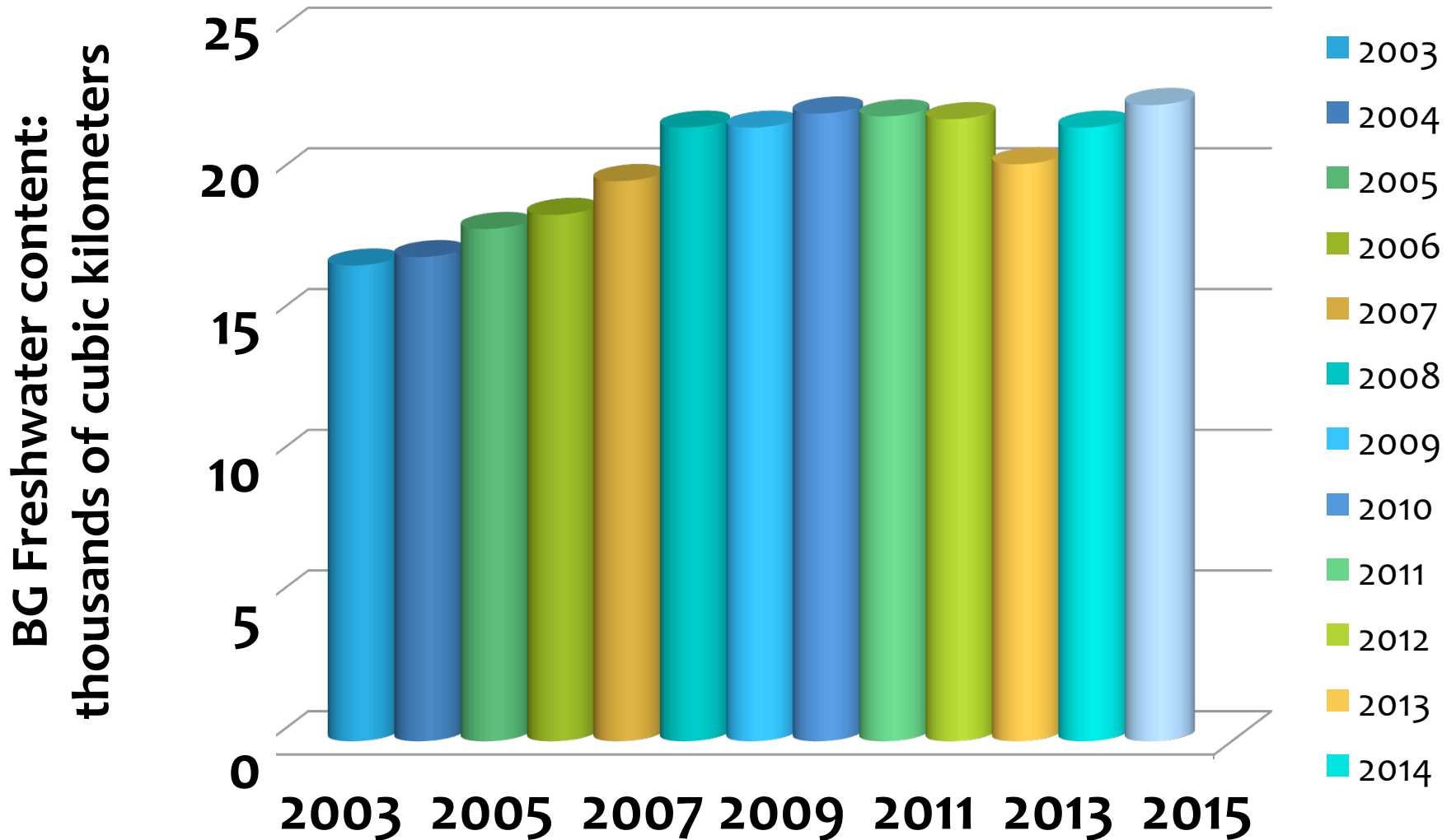

BGOS major results: Freshwater

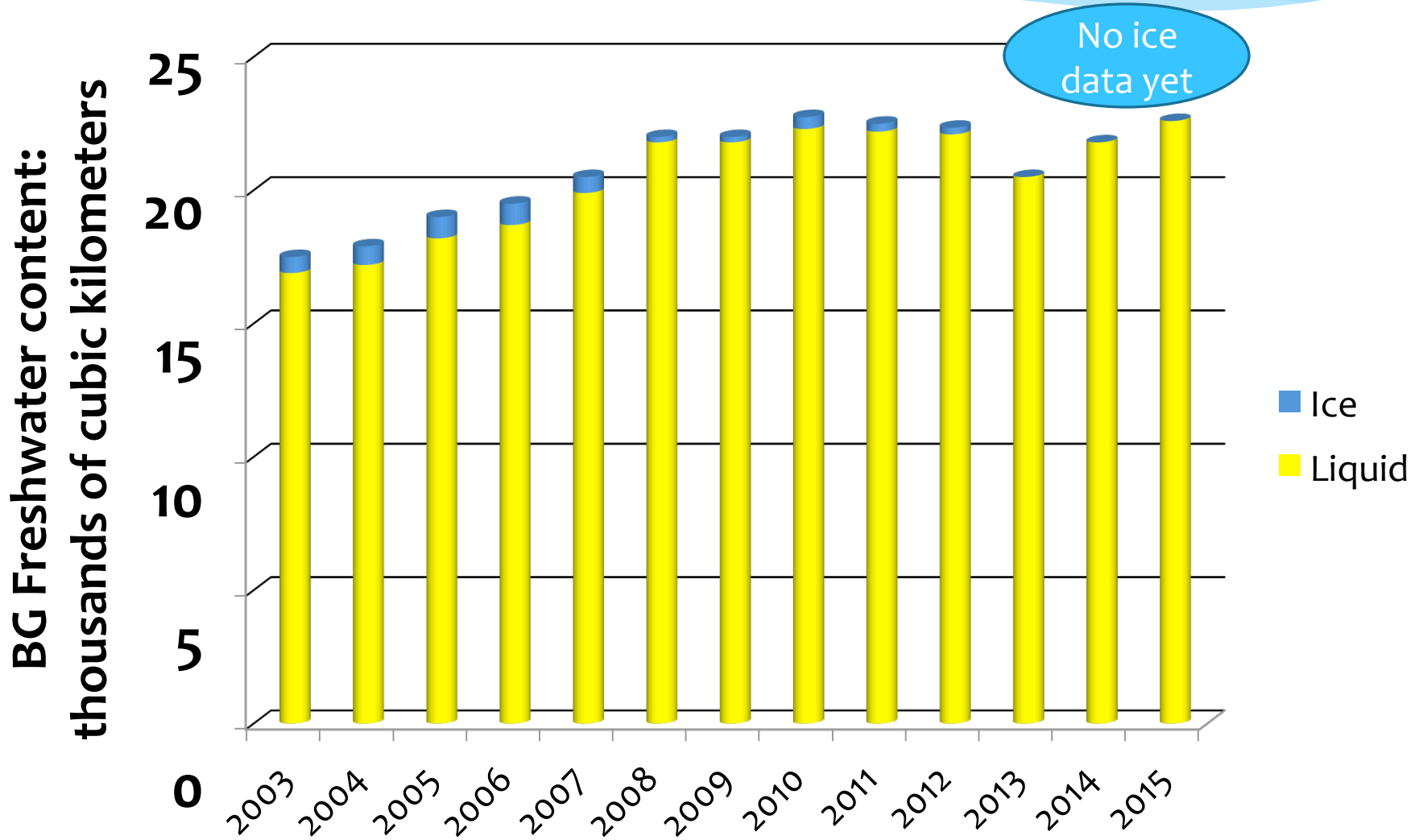

BGOS major results: Circulation

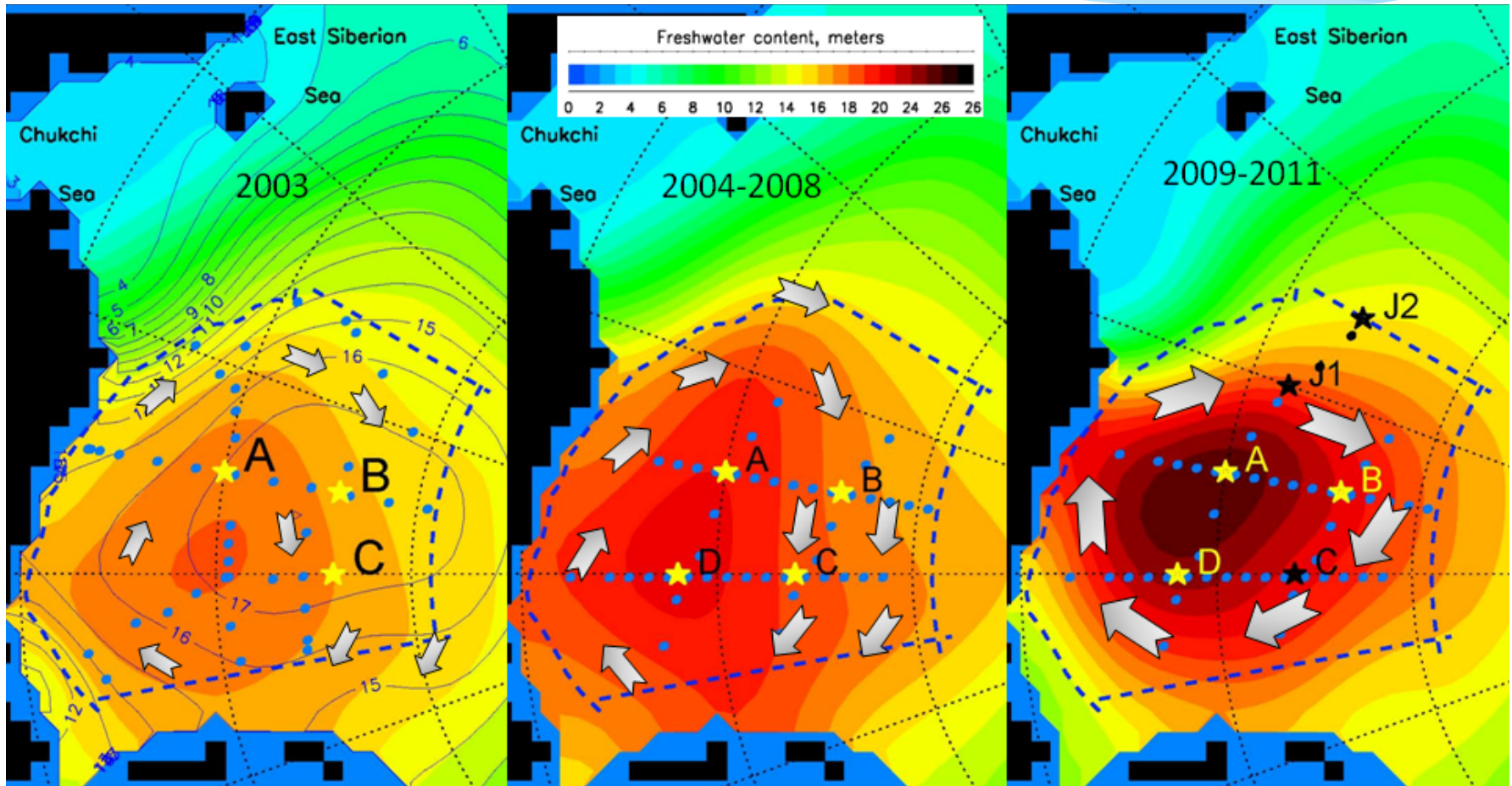

see Proshutinsky et al., 2009; McPhee et al., 2009; McPhee, 2013

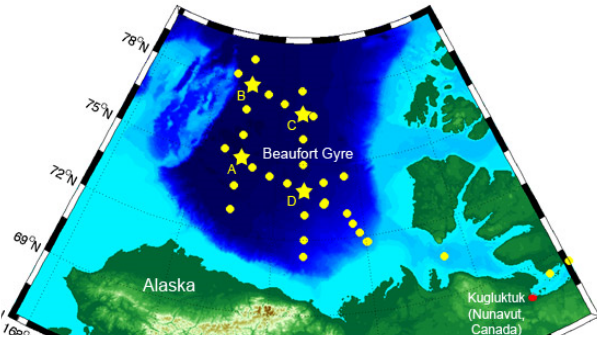

BGOS major results: Ice draft

Ice draft anomalies, meters

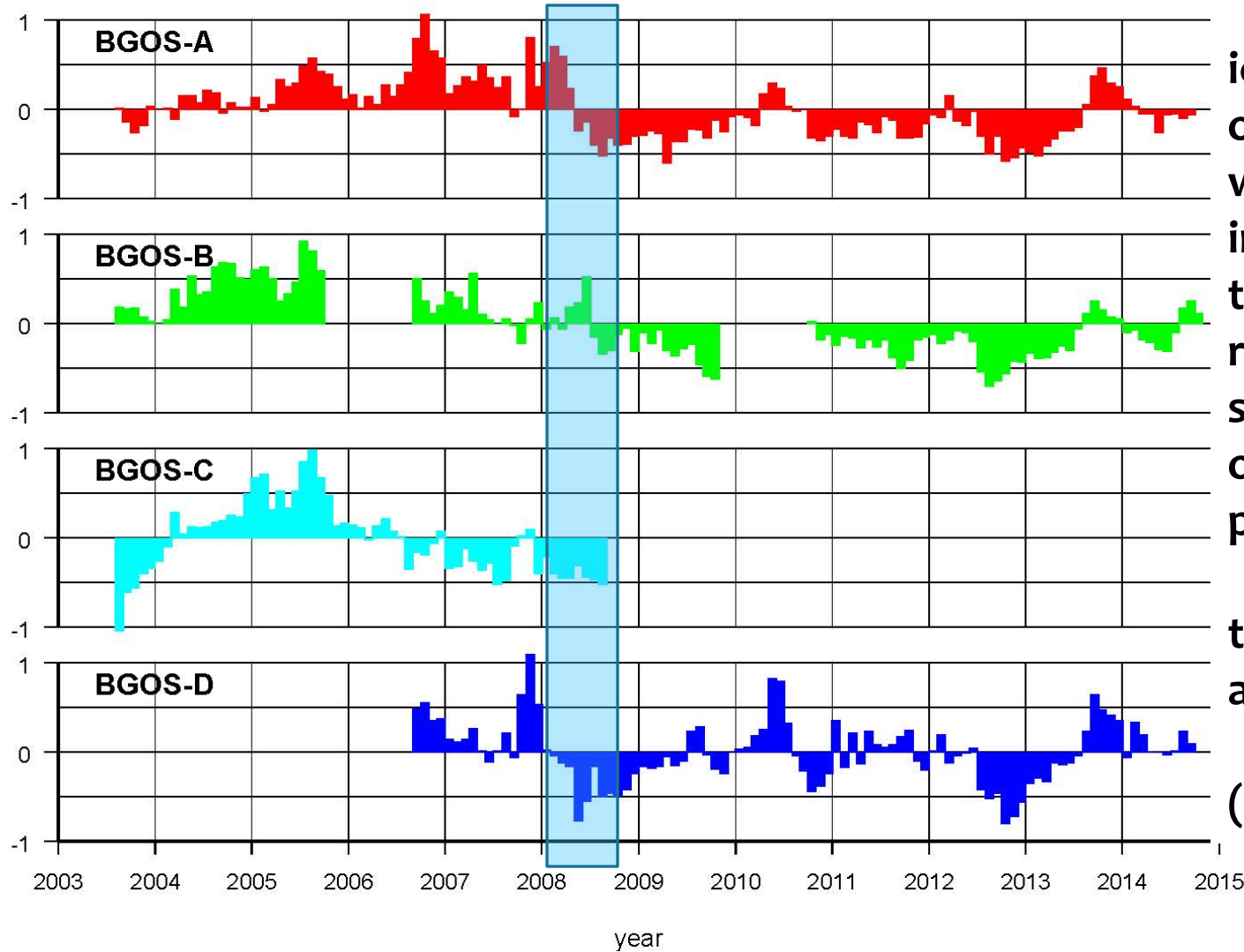

Negative trends in ice drafts are observed, while open water fraction have increased, attesting to the ablation or removal of the older sea ice from the BG over the observational period.

A shift occurred toward thinner ice after 2007.

(Krishfield et al., 2014)



BGOS major findings: Geochemistry

Freshwater composition: During the rapid increase in BG freshwater content over 2005-2007 sea-ice meltwater increased by 2.7 m in the central BG region and low-salinity water from the Mackenzie River was advected to the southern BG region. (Yamamoto-Kawai et al., 2009a)

Ocean acidification: Surface waters of the BG became undersaturated with respect to aragonite in 2008 - the first sign of acidification in the global deep ocean (Yamamoto-Kawai et al., 2009b). Three factors contributed: reduced sea-ice extent (~30%), increased sea-ice melt (~30%), and anthropogenic CO₂ (~40%). The deeper Pacific Winter Water is also undersaturated, due to anthropogenic CO₂, with negative implications for shelled benthic organisms during upwelling to shelf ecosystems (Mathis et al., 2011).

BGOS major findings: Geochemistry

Organic carbon cycle: Hwang *et al.* (2008) analyzed sediment traps at BGOS mooring A, finding that, unlike other ocean basins, the bulk of particulate organic carbon entering the deep BG region is supplied by horizontal advection from the surrounding margins and that both the organic and inorganic carbon cycle in the Arctic is inherently linked to ocean dynamics.

Ecosystem Effects: McLaughlin and Carmack (2010) noted that FW changes from 2007 to 2009 in the BG depressed the top of the halocline and increased the stratification there by 25%, thus deepening the upper nutricline and associated summertime subsurface chlorophyll maximum and making nutrients less available. These harsher conditions coincided with a shift in near-surface ecosystem structure towards the smallest plankton (Li *et al.*, 2009).

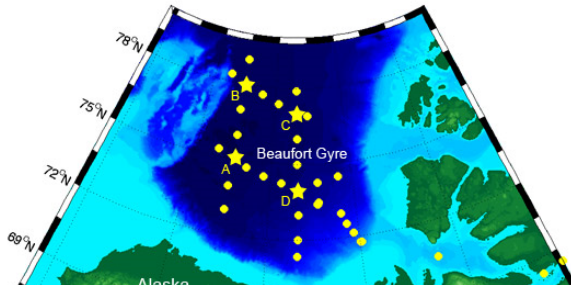

BGOS: other observations

Mike DeGrandpre (Department of Chemistry and Biochemistry University of Montana) asked me to show you these results (left figure) from moorings recovered in October 2015 BG cruise. pCO₂ sensor was located at 37m depth at mooring B and pH sensor at Mooring. It is assumed the big pCO₂ swings at mooring B are due to eddies. These are also collected within the halocline (not in the mixed layer) and so have variability due to that, although not as evident under ice.

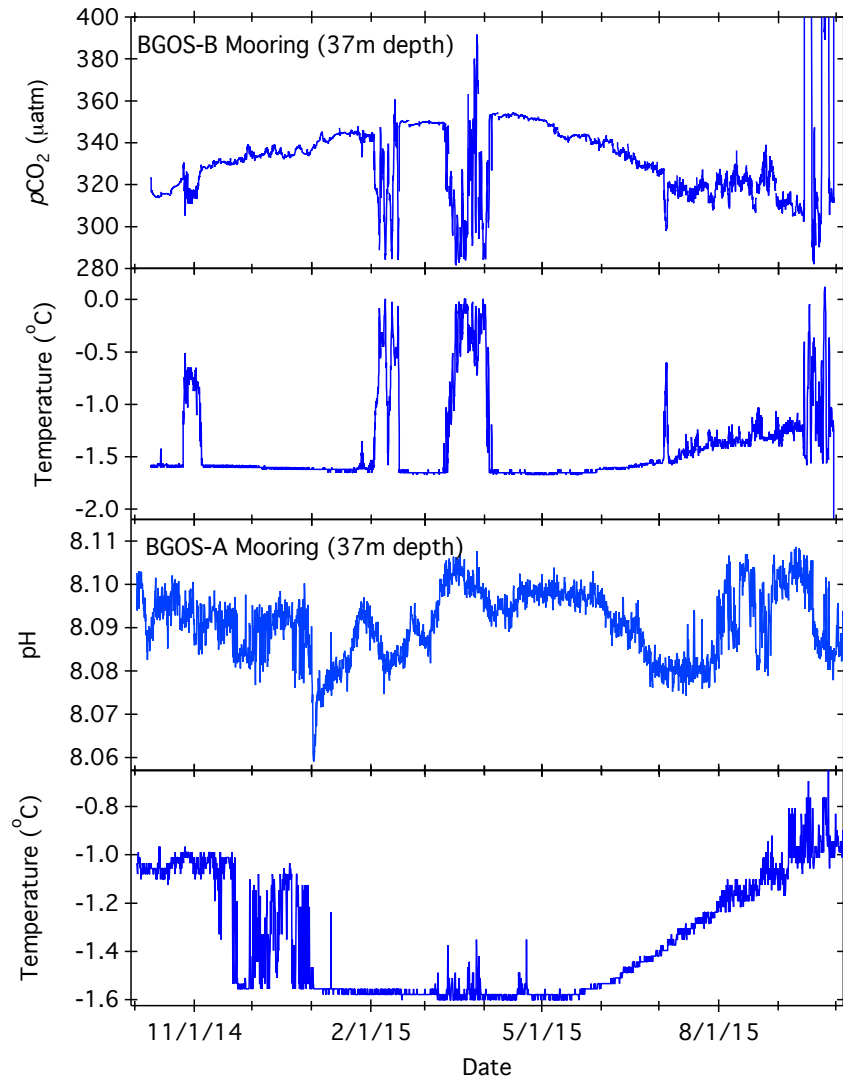

The pCO₂ begins to drop in early May, presumably due to biological production. The slight warming would increase the pCO₂ slightly, so the production is counteracting that.



Hypothesis: BG and circulation regimes

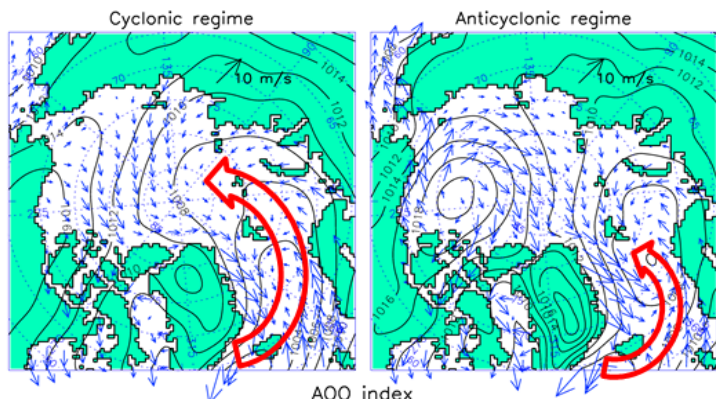

AOO index

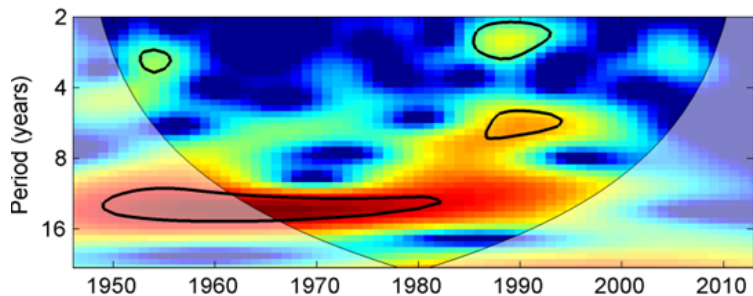
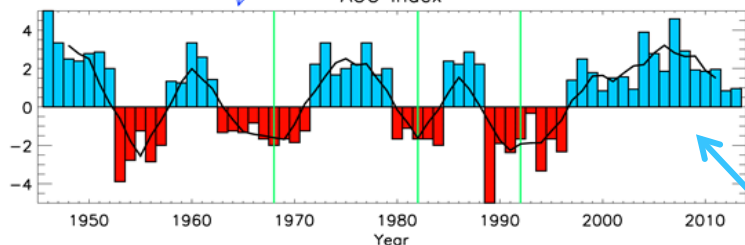

Arctic FW

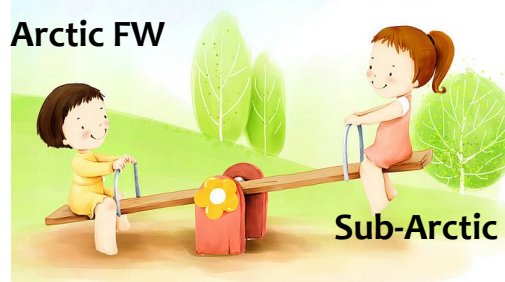

Sub-Arctic heat

1946-1996 decadal oscillation

Greenland FW



1997-2015: 17 year of ACCR

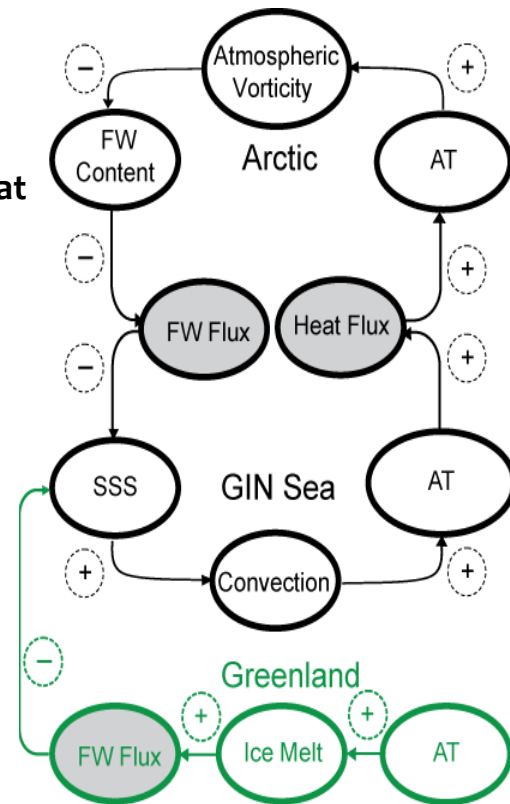

We speculate that longer duration ACCRs could result in Arctic cooling accompanied by increased ice extent and thickness—similar to conditions observed in the 1970s. (see Proshutinsky et al. (2015) Arctic circulation regimes, Philosophical Transactions A of Royal Society; in “Arctic sea ice: the evidence, models and impacts”, doi.org/10.1098/rsta.2014.01600